



Installation Instructions

Vehicle Application

Year: **2011-12**
 Make: **CHEVY/ GMC**
 Model: **2500HD/ 3500**
 Engine: **6.6L Duramax LML**

Tools Required

- 8mm & 10mm Wrench & Socket
- T-20 Security Torx Wrench (Supplied w/ Kit)
- 7/16" Wrench and Socket
- 5/16" Nut Driver or Flat Blade Screwdriver
- Phillips Screwdriver, Pliers or Channel locks

S&B Filter Maintenance

Cleanable (KF-1052). If the enclosed filter is Red, it came pre-oiled from the factory. Please visit www.sbfilters.com for exact oil amount required after cleaning.

Disposable (KF-1052D). If the enclosed filter is White, it is a disposable filter and should be discarded once it reaches capacity. This filter (does not require oil). For more info on S&B's disposable filter, visit www.sbfilters.com.

Notes

Kit may not fit with the following Aftermarket Parts installed:

- Body Lift or Lowering Kit
- Custom Hood
- Intercooler or Turbo upgrades

CARB Status - Exempt

CARB EO #: D-590-6

Legal for use in CA or other states adopting CA emissions standards
 See Page 3 for more info.

Before You Start

- Please read the entire product guide before proceeding.
- Ensure all components listed on page 4 are present.
- If you are missing any of the components, call our customer support at (909) 947-0015.
- Do not work on your vehicle while engine is hot.
- Make sure the engine is turned off and the vehicle is in Park or the Parking Brake is set.

1. With the ignition switched off and the parking brake set, disconnect the negative battery cables on both batteries.



2. Disconnect the electrical connection for the Mass Air Flow (MAF) Sensor.



3. Loosen the hose clamp at the turbo mouthpiece.



4. Loosen the hose clamp connecting the intake tube to the air box lid. Then remove the intake tube from the truck.



5. Remove air box lid and air filter by removing the two screws by the fender. Then carefully pull the lower portion or the air box up out of the two rubber grommets.

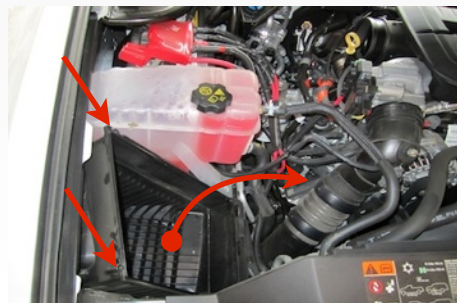

6. Remove the four bolts mounting the air box tray. Remove the mounting tray from the truck. Save all hardware.

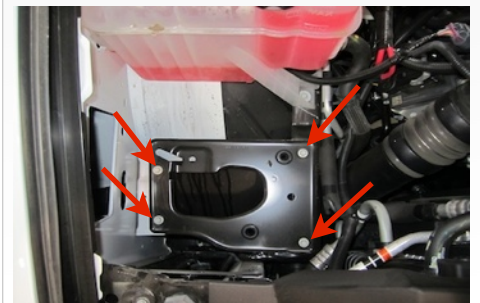

7. Between the battery and the fender; remove the nut mounting the coolant reservoir.



8. Unsnap the plastic clip holding the coolant reservoir to the AC line using a flat blade screwdriver. Then remove the other screw mounting coolant reservoir.

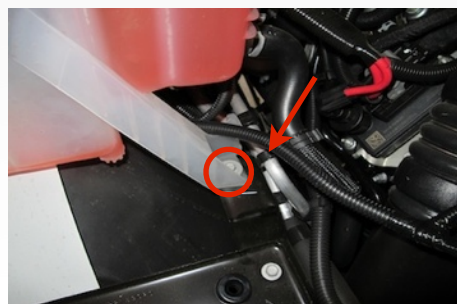

9. Remove the MAF sensor from the OE air box lid. Using the two supplied #8-32 Screws (Q) and Plastic Spacers (P), install the MAF sensor into Intake Tube (L). Do not over tighten.



SEE EXPLODED VIEW ON PAGE 4



Installation Instructions (continued)

10. Place the Silicone Adapter (R) and both #72 Hose Clamps (O) onto the turbo inlet mouthpiece. Tighten the clamp on the turbo mouthpiece only.



11. Place the Adapter Tube (D) into the base of the S&B Air Filter (E) and tighten the #96 Hose clamp (F). Remove the Filter minder and grommet from the OE air box lid, then re-install them into the Adapter tube (D).



12. Slide the two #80 Hose clamps (N) over the Hump Adapter (M). Then push the Hump adapter (M) over the Adapter tube (D). Leave clamps loose for now.



13. For those concerned about minimal engine heat; insert the four Clip Nuts (S) over the holes on the bottom opening of the Air Box (A), insert the Box Plug (T) into the end of the Air Box (A). Attach using the supplied 1/4-20 Hex Screws (U) and Flat Washers (B) from the inside of the Air box using 5/16" socket or ratcheting wrench. For those seeking additional air flow, set the Air Box End Cap aside and save all the supplied hardware. (See page 3 for more info)



14. Move the coolant reservoir out of the way. Install the Air Box (A) using the two supplied M6x30mm screws (C) and 6mm Washers (B) for the two holes closest to the fender. Use the OE screws for the other two holes. Tighten all four.

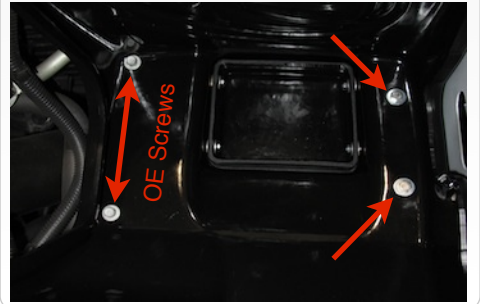

15. Reinstall the coolant reservoir mounting hardware that was removed in Steps #7 and #8.



16. Carefully place the filter assembly into the Air Box (filter end first) trying not to ding or gouge the filter element. Rotate the Filter Adapter assembly into position and hook the clip into the Air Box.



17. Route the MAF sensor wiring harness as shown. Then install the Intake Tube assembly into the Silicone adapter (R).



18. Slide the Hump Adapter (M) over the Intake Tube (L). When satisfied with the positioning, tighten the two #80 hose clamps (N) and #72 Hose clamp (R) at the turbo.



19. Reconnect the MAF sensor wiring harness to the MAF sensor.



20. Install the Clear Lid (G) using the supplied 5/16" S.S. Screws (I) and Rubber Washers (H) along with the 10-24 Screws (K) and SS Sealing Washers (J). This will secure the Filter Adapter to the Air Box as well. (Do not over tighten!)

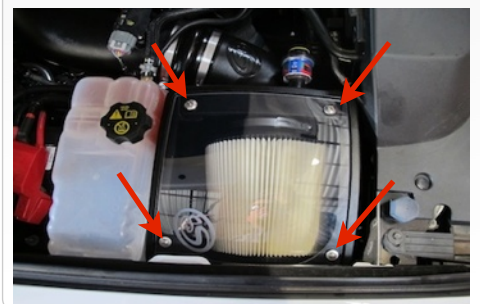

SEE EXPLODED VIEW ON PAGE 4



Installation Instructions (continued)

21. Reconnect both batteries. Inspect your installation, make sure the kit is properly positioned and all fasteners are secure. Affix the CARB sticker near the intake kit. The installation is now complete.



Precision II Filter Cleaning & Oiling



Order online today at www.sbfilters.com or through your local S&B distributor.
Part #: 88-0008

RELATED ITEMS FOR YOUR PURCHASE

- Replacement Air Filter (Oiled) (S&B P/N: KF-1052)
- Replacement Air Filter (Dry) (S&B P/N: KF-1052D)
- Air Filter Wrap (S&B P/N: WF-1033)
- Air Scoop - Chevy Models (S&B P/N: AS-1000)
- Air Scoop - GMC Models (S&B P/N: AS-1001)

Performance Testing

- Engage parking brake and start your engine. Listen for abnormal noises. If an air leak is detected, re-inspect hoses and connections as they may need to be repositioned and tightened.
- S&B FILTERS recommends that you keep your OE intake system in the event it is required in the future.
- In order to maintain your warranty, all connections and components must be checked periodically for alignment and for proper tension on all connections. Failure to do so may void your warranty.
- Use only S&B FILTERS cleaning and oil products to service your filter. Using any other brand oil and or cleaners on your S&B air filter may void your warranty.

Air Box End Cap Testing

Stock air boxes are a significant contributor to poor air flow which is why S&B designs custom air boxes with secondary and/or enlarged openings. With that said, S&B recognizes the benefits of cooler air, so we have included a plug to seal off the opening if so desired. For optimal performance, we recommend that the intake be used without the end cap except in conditions of extreme heat.

Warning!

If your vehicle has a Vehicle Emission Control Information decal affixed to the factory airbox, a new replacement label must be obtained and installed in a readily visible position in the engine compartment in order to remain CARB compliant. Failure to do so will prevent the vehicle from passing a smog check. Replacement labels can be ordered from your local dealership. Regulations state that the VEI label shall not be affixed to any equipment which is easily detached from the vehicle. Label placement, under the hood on a painted surface is recommended.



Emissions Standard

The California Air Resource Board (CARB) requires that an E.O. identification label be applied to the vehicle in order to pass a smog check inspection when a Performance Intake Kit has been installed. You must place the E.O. label provided on or near the intake kit after installation so that a smog check technician can easily verify the E.O. number. As of April 2009, S&B has never had a product where CARB denied an exemption request; however, the exemption process with CARB can take as long as 18 months. Check the status of the exemption process by looking up a specific part number at www.sbfilters.com. The CARB Exemption number and/or status is listed under the Product Details section for each part number. If the status shows as "Pending," CARB has yet to issue an exemption but the product has been submitted. Products that have not been issued an EO number are street legal in most states, but may not be used on emission controlled vehicles in the state of California and are for off road use only. If you purchased your kit from S&B Filters directly, we will automatically mail you your Exemption Sticker when it is issued to us. If you purchased your kit from an authorized S&B Filters Dealer, log onto our web site and register to receive your Exemption Sticker.

SEE EXPLODED VIEW ON PAGE 4



Exploded View

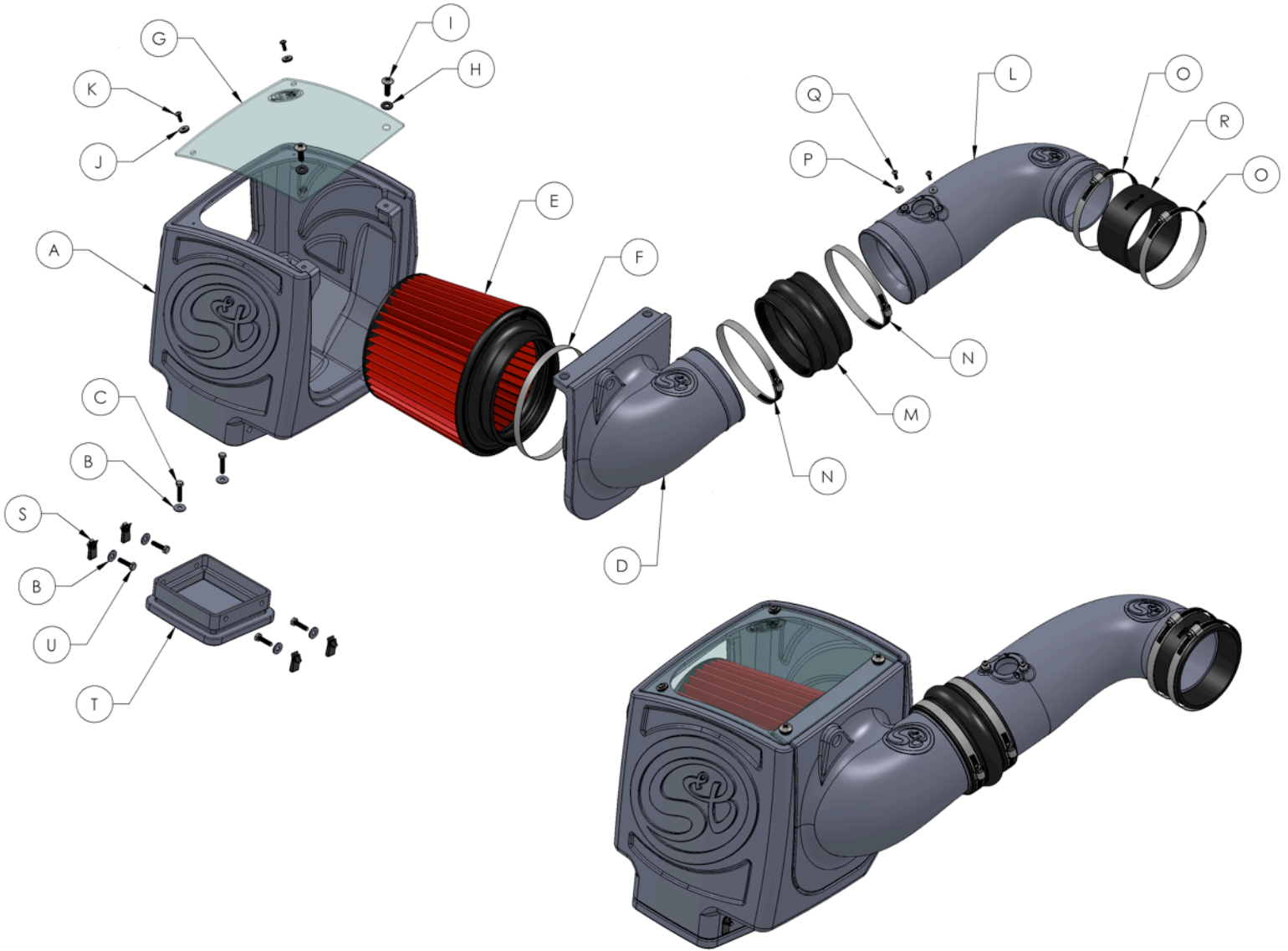

ITEM	QTY.	DESCRIPTION	P/N
A	1	Air Box	AL1167-00
B	6	Washer, Flat, 6mm	AI1535-00
C	2	Screw, Hex Head, M6 x 30mm	AI1257-00
D	1	Adapter Tube	AL1168-00
E	1	S&B Air Filter	KF-1052
F	1	Hose Clamp, #96	AG1026-00
G	1	Clear Lid	AI1528-00
H	2	Washer, Rubber Sealing	AI1435-00
I	2	Screw, Truss Head, 5/16" x 1"	AI1297-00
J	2	Washer, S.S. Sealing	AI1272-00
K	2	Screw, Pan Head, #10-24x1/2"	AI1287-00
L	1	Intake Tube	AL1169-00
M	1	Hump Hose, 5"ID x 3"Long	AI1338-00
N	2	Hose Clamp, #80	AG1010-00

ITEM	QTY.	DESCRIPTION	P/N
O	2	Hose Clamp, #72	AG1009-00
P	2	Washer, Spacer, .125"thk.	AI1536-00
Q	2	Screw, Pan Head, #8-32x1/2"	AI1479-00
R	1	Silicone Adapter, 4.00"IDx2.50"	AI1354C-00
S	4	Clip Nut, #1/4-20	AI1059-00
T	1	Box Plug	AL1176-00
U	4	Screw, Hex Head, #1/4-20x1.0"	AI1131-00

AM0174-00 Rev.E 09/26/13

Warranty
Visit www.sbfilters.com for complete warranty information.